

Intelligent-Based Control System for Effective Road Traffic Management in Nigeria: A Proposed Model

¹ Salisu Umar, ²Engr. Sadiku, L. U., *B.Eng, M.Eng, MNSE, MNIEEE*, ³Engr. Danladi Agadi Tonga

*Department of Mechatronics Engineering, Hussaini Adamu Federal Polytechnic, Kazaure Nigeria
Electrical & Electronic Department, Hussaini Adamu Federal Polytechnic Kazaure, Jigawa State Nigeria*

ABSTRACT

The increase in urbanization and traffic congestion in Nigeria create urgent need to operate our transportation systems with maximum efficiency. The effective method employed to minimized the problem associated with traffic congestion is through se of information technology where use of commuters to inform the general public, and detect emergency vehicles such as those of fire brigades, VIPs and ambulances and give them priority over other vehicles. Unfortunately, most existing traffic control systems in Nigeria are based on fixed time concept allotted to each side of the junction which cannot be varied as per varying traffic density, therefore lack intelligence and capability to optimally control and manage traffic. The proposed intelligent-based control system (IBTCS) in this paper intends to provide solutions to the problem of traffic congestion and traffic management using real time image and video processing techniques. It comprises high resolution video cameras mounted on the road sides for capturing traffic images, an ARM7 microcontroller which takes decision based on vehicle count and other information from Raspberry-pi, updates the traffic light delays and changes signal timing automatically based on traffic density which corresponds to area occupied by vehicles on the roads in terms of total amount of pixels in the video frame. Subsequently, the number of vehicles at the intersection is evaluated and traffic is efficiently managed. A barrier gate embedded into the system is meant to prevent traffic offenders while the plate number of such vehicle and other information are sent through GSM technology. In case an emergency vehicle is detected, that lane is given priority irrespective of its traffic density. This model employs RFID for detecting stolen vehicles while alerting the security personnel by activating the buzzer and barrier gate. It also uses the GPS and GSM technologies for providing traffic and accident information to the general public and appropriate authorities.

Keywords: *IBTCS, traffic density, traffic management, image processing technique*

1.0 INTRODUCTION

As the population of the modern cities and vehicular travel are increasing day by day, traffic mismanagement and congestion have been the critical problems in the urban environment. These have resulted in long waiting times, waste of fuel and environmental pollution [2, 8]. These negative effects are more acute in developing countries like Nigeria, where infrastructural development is slow because of cost and bureaucratic issues. It is therefore utmost necessary to have a fast, economical and efficient intelligent traffic management system that provides traffic information to commuters and helps to alleviate congestion issues [6]. It is worthy of notice that the leading causes of fatalities is traffic accidents due to over-speeding, over-taking and non-compliance of the road traffic signs [7]. A report from World Health Organization adjudged Nigeria the most dangerous country in Africa with 33.7 deaths per 100,000 populations every year. Investigation by Economic Intelligence Magazine further revealed that out of 49,867 persons involved in road accidents between 2013 and 2015, 15,011 people were killed while 34,856 people were injured. Fig. 1 and fig. 2 showed that reckless driving contributed 30.3% of road accidents while motor cycle-motor cycle collision and motor cycle-vehicle crashes contributed 38.9% and 37.5% of deaths recorded respectively from the year 2013 to 2015. These buttresses the fact that road accident has adversely affect the lives and property of Nigerians.

It is has been predicted that unless action is taken, road traffic accident will become the 5th leading cause of death by 2030. Unfortunately, the present traffic control system which is based on time constant lacks intelligence and capability to solve these problems especially as most urban areas in Nigeria tend to migrate to smart cities. The proposed IBTCS intends to implement an intelligent traffic controller using real time video and image processing techniques. The video frames from cameras are analyzed using ‘thresholding method’ to find the traffic density. The number of vehicles at the intersection is evaluated and traffic is managed efficiently. Once a particular lane is cleared by showing ‘GREEN’ on the traffic LED, other lanes will be shown ‘RED’ while the actuating signal is sent to the barrier gate drivers of these lanes thereby preventing traffic offenders. The plate number of vehicle crossing the marked line while the traffic LED is showing RED will be captured and sent to the appropriate authority through GPS technology. It detects stolen vehicles on getting to the traffic light with the aid of RFID and activates buzzer to alert the security personnel of the presence of such vehicles. IBTCS also implemental real-time emergency vehicle detection and notification systems which senses when traffic accidents occur and immediately notify the location of accident to emergency personnel by use of GPS technology while it provides traffic information to commuters and general public using GSM technology. In case an emergency vehicle is detected, the lane is given priority over the others. Hardware processing and control are done by Raspberry-pi and ARM7 microcontrollers. Therefore, IBTCS proves to be better option for effective road traffic management.

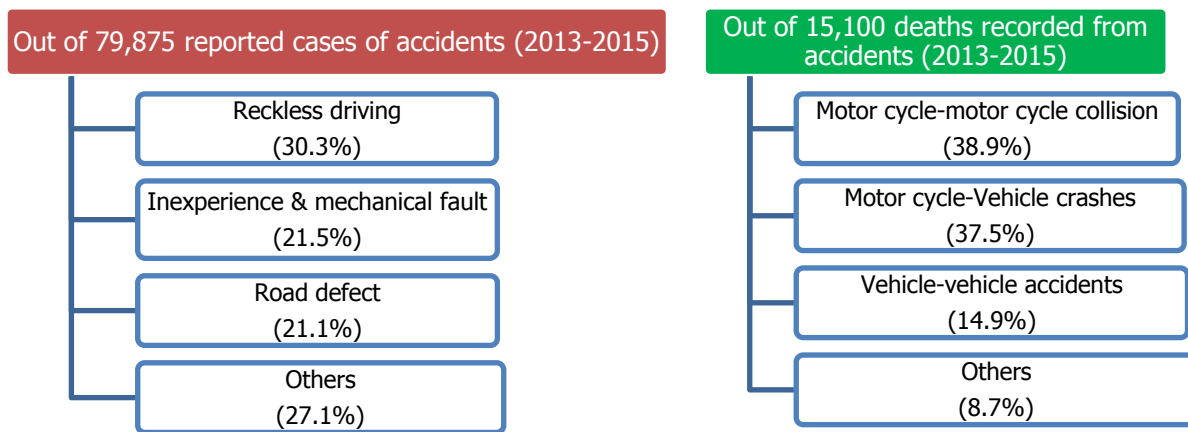

Fig. 1 Report on different causes of accidents (Data adapted from analysis by Economic Confidential)

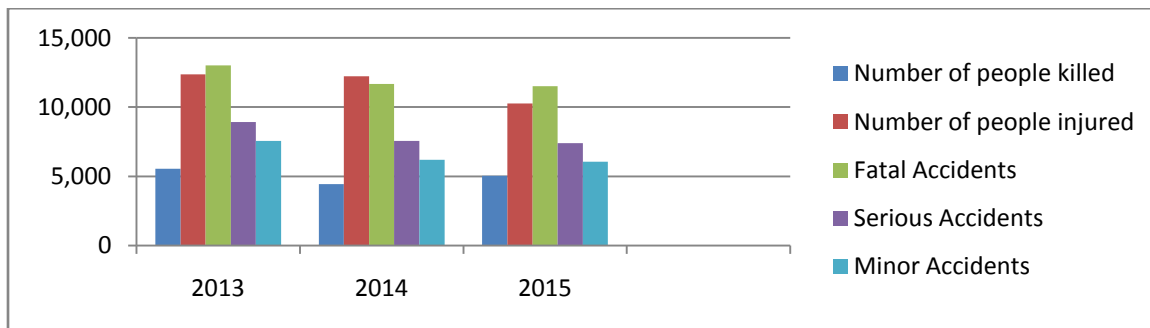

Fig. 2 Report on effects of road accidents from 2013 to 2015 (Data adapted from analysis by Economic Confidential)

2.0 EXISTING METHODS OF ROAD TRAFFIC CONTROL SYSTEM

The existing methods of controlling road traffic are classified into two. They are:

- i. Manual traffic control, and

ii. Automatic traffic light control

2.1 Manual Traffic Control: This requires man power to control the traffic. Depending on the countries and states, the traffic police men are allotted for a required area or city to control the traffic. They may wear specific uniforms and employ things like sign board, sign light and whistle to control traffic.

2.2 Automatic Traffic Light Control: This involves timers and electrical sensors. The lights are automatically getting ON and OFF depending on the time constant.

Some of the limitations of the existing traffic control systems are as follow:

- Heavy traffic congestion.
- No traffic, but still need to wait.
- Emergency vehicles stuck in traffic congestion.
- Inability to adequately provide traffic information to commuters and appropriate authorities.

3.0 THE PROPOSED MODEL

The proposed model uses video and image processing technique to efficiently control traffic based on vehicular density. Video cameras are installed on the road alongside the traffic light to capture the image sequences. The video frame obtained is processed, determine the vehicular density and take appropriate decision. Consequently, the possibility of traffic congestion is greatly minimized by allowing the passage of vehicles on the road with highest traffic density. The proposed model gives priority to emergency vehicles like those of ambulance, security, fire brigade and VIP etc. It employs GSM technology to make available the traffic information to the general public while preventing traffic offenders using barrier gate. Upon the passage of vehicle, it detects stolen vehicle by comparing the unique RFID tag read by the RFID reader to the stolen RFIDs stored in the system. If a match is found, an SMS is sent to the mobile number of the authorized personnel specifying the RFID number and plate number using GSM technology. The LCD will indicate the INVALID VEHICLE (see fig. 3) and alerts the security agencies by activating the buzzer and barrier gate. Whenever accident occurs, it immediately notifies the location of accident to the emergency centers through GPS technology. In the event of emergency vehicles, the proposed model will use the existing GPS hardware in most smart phones to receive and transmit GPS signals. An ambulance or emergency vehicle (with an android device or whose staff carries smart phones) receives GPS coordinates from satellites and then transmits the coordinates to the web server (see fig. 4). The web server in turn computes position, speed and other factors and then sends pre-emption commands to the corresponding traffic signal to give priority to the ambulance vehicle irrespective of traffic density. Therefore, the proposed model proves to optimally reduce traffic congestion and avoids the time being wasted by a green light on an empty road. It is more consistent in detecting vehicle presence because it uses actual traffic images. It also provides the necessary traffic data or information required of highway engineers in road design and construction as well as researchers in related fields. More so, it visualizes the reality hence functions much better than the existing control systems.



Fig. 3 Invalid vehicle detection



Fig. 4 Communication between ambulance vehicle, Satellites, web server and traffic LED

3.1 Aim of the Proposed Model

The aim of the proposed model is to suggest an intelligent based control system for efficient road traffic management using video and image processing techniques.

3.2 Objectives of the Proposed Model

The main goal of the proposed model is broken down into specific objectives as shown below;

- To reduce the potential traffic congestion using traffic density for traffic control replacing the existing traffic system which is based on time constant.
- To give priority to emergency vehicles like those of fire brigades, ambulances and VIPs to pass irrespective of the traffic density.
- To provide traffic information and accident scenes to commuters, appropriate authorities and the general public.
- To detect stolen vehicles before passing the traffic light and alert the security personnel immediately.
- To prevent traffic offenders by activating the barrier gate and the buzzer.
- To realize and implement a system that serves as archive of traffic data for researchers and highway engineers.

3.3 Proposed Model Architecture

The model architecture showing different components and system configuration is shown in fig. 5 below:

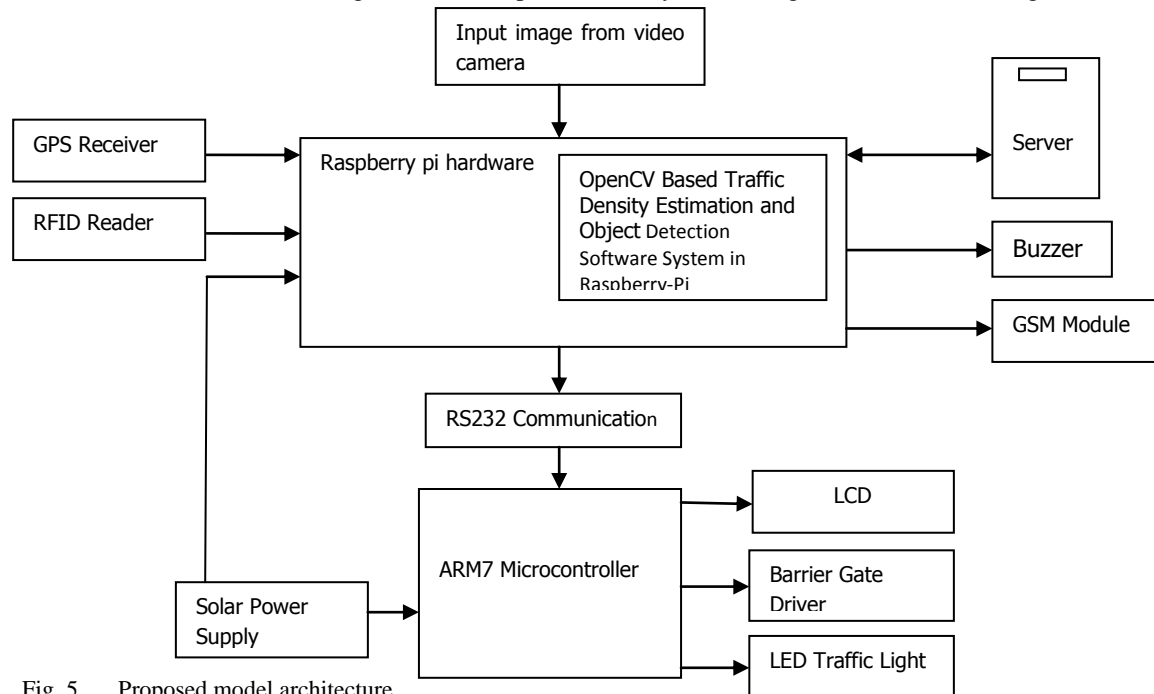

Fig. 5 Proposed model architecture

3.4 Operation Mode of the Proposed Model

The proposed model operates in dual mode; normal mode and emergency mode. This is highlighted below:

- **Normal Mode:** At normal mode, it operates the traffic signal lights and activate barrier gate driver based on traffic density.
- **Emergency Mode:** It turns to this mode when an emergency vehicle is approaching the traffic light on a lane. Upon receiving preemption commands from the web server, it switches to emergency mode smoothly by changing signal lights appropriately. It also switches to emergency mode when stolen vehicle is detected.
- It accepts return-to-normal mode commands from the web server and switch back to Normal mode.

3.5 Methodology of the Proposed Model

To realize the proposed model, the following methods were adopted as highlighted below:

- a. **Image acquisition :** The image of the vehicle is captured using video camera and transferred to the image Processing system in OPEN CV software environment
- b. **Image pre-processing:** The acquired image is enhanced using contrast and brightness enhancement techniques.
- c. **Gray scale conversion:** This involves conversion of colour image into a gray image. This method is based on different colour transforms.
- d. **Image Binarization:** Gray scale image is converted into black and white image i.e. binary image using thresholding operation.
- e. **Identify ambulance:** By using Binary image, morphological filtering and Blob analysis ambulance is detected.
- f. **Send ambulance signal to the Raspberry-pi:** The identified ambulance signal is send to raspberry -pi, and then to the ARM7 microcontroller for signal changes.

3.6 Proposed System Flow

To achieve the objective of the proposed model, the system flow followed is depicted in fig. 6:

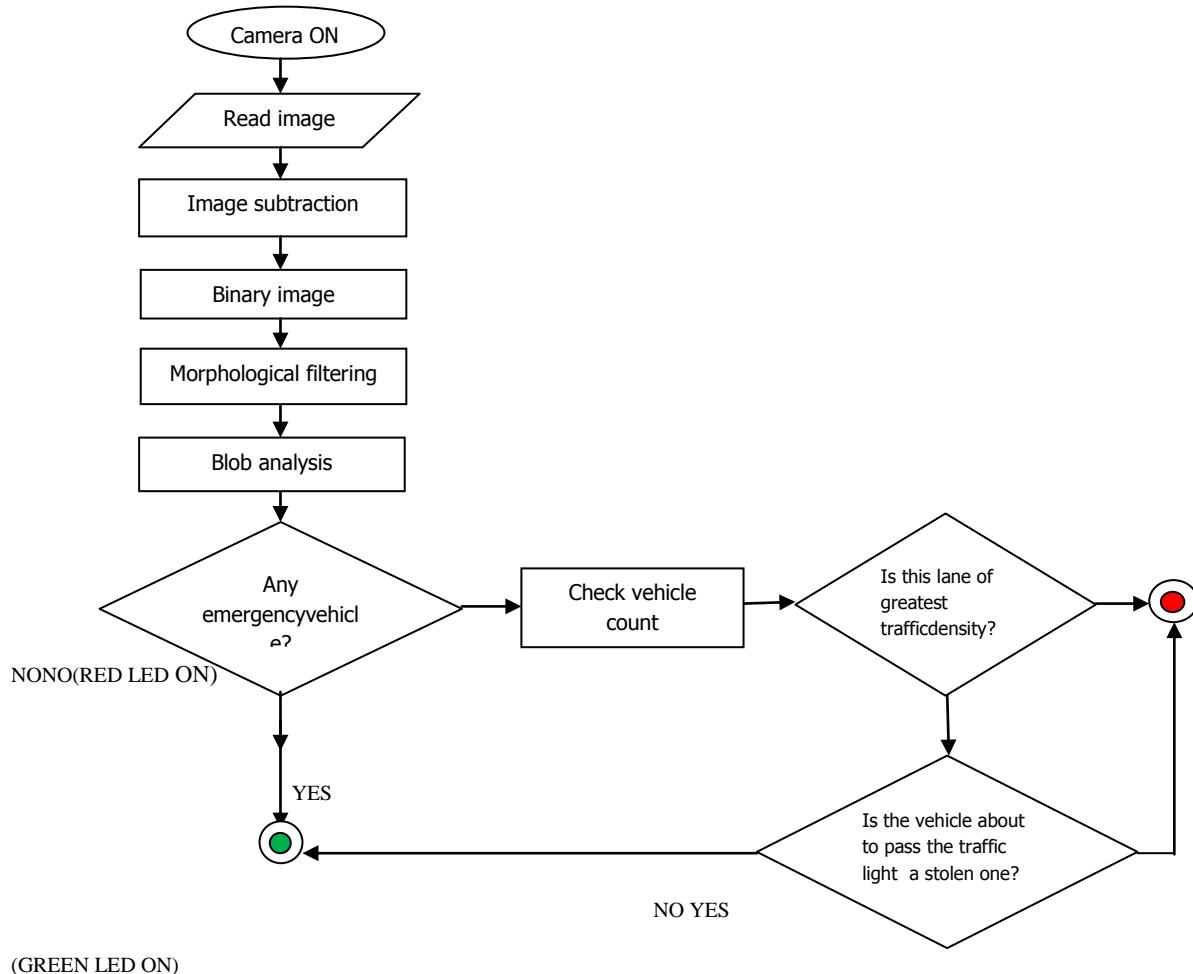

Fig. 6 Proposed model flow for traffic light control

The algorithm of the proposed model as shown in fig.6 is highlighted in step-wise as follow:

- **Camera:** Video camera continuously record traffic video.
- **Read Image:** This involves reading one video frame per second from videocamera using video and image processing techniques.
- **Image Subtraction:** At this point, the current image of traffic is subtracted from the background (i.e. image without vehicles previously saved as initial condition).
- **Conversion of image to Binary** i.e.
 - Creates black and white image.
 - Vehicle=White ; Background= Black
- **Morphological Processing:** This involves image filtering using two processes as thus:
 - Open: Remove White dots other than vehicle.
 - Close: Remove Black dots other than background.
- **Blob Analysis:** The processes involved are as follow:
 - Check the current density of the vehicle.

- Verify whether or not emergency vehicle is present.
 - ❖ If present, then generate green signal for the emergency vehicle
 - ❖ If present in all the lanes/roads, generate green signal for the first in time; in that order
 - ❖ If not, then count the number of vehicles in each lane and generate **green signal** for the one with the greatest vehicular density, and **red signals** for other lanes.
 - ❖ Verify whether or not tag on the vehicle which is about to pass the marked line is a stolen one.
 - If yes, change the **green signal to red signals** and activate the buzzer and barrier gate while displaying the message 'INVALID VEHICLE' on the LCD.
 - If no, maintain the **green signal**.

3.7 Benefits of the Proposed Model

Some of the benefits of the proposed model if fully implemented include the following:

- Reduction in waiting time due to the fact that traffic signals change according to traffic density.
- Minimizing road accidents as it uses barrier gate to prevent traffic offenders from gaining access.
- Effective control and management of road traffic especially in the presence of emergency vehicles like ambulance, fire brigade, police, etc.
- Detection and notification of stolen vehicles.
- Reduced production and maintenance costs.
- Provision of traffic data for researches and high way design and construction.

4.0 HARDWARE SPECIFICATIONS

a. Raspberry-pi device: The raspberry-pi is based on a Broadcom SoC with an ARM processor. Detail specifications of the device is as follow:

- Model: B+
- Processor: 700 MHz, ARM1176JZF-S core (ARM11 family, ARMv6 instruction set).
- RAM: 512 MB.
- USB: 4 on board.
- Storage: MicroSD card.
- Voltage: 600mA up to 1.8A at 5V.
- GPO: 40.

Therefore, Raspberry-pi provides a real world performance. Its GPU gives 1 Gpixel/s of general purpose computing performance while a RAM of 512 MB (CPU RAM) is sufficient for standalone 1080p video decoding or for simple 3D.

b. Power supply: A 5 V DC power supply is required. Solar power supply is recommended as alternative.

c. Liquid Crystal Displays (LCD): The threshold voltage for watch type LCD displays is 1 to 2V. The LCD comprises two modes; **N** (normal mode) and **C** (highest density). If it displays 'NNNN', it means no traffic density on the four lanes. The moment there is traffic density in lane 1; for example, it will display 'CNNN', which means that lane 1 has the highest traffic density and then cleared.

d. ARM7 Microprocessor: ARM7 processor is preferred in the proposed model due to its advanced features. 32-bit ARM processor is the contemporary general purpose microprocessor on the embedded market used in industrial level applications. ARM7 is interfaced a number of peripherals like keypad matrix, LCD display, UARTS, GPIO and I²C protocol. ARM7 processor is a link between GPS and GSM modules for communication.

e. GSM Module SIM 300: GSM modem is connected with the Raspberry-Pi. This allows for communication over the mobile network. The GSM modem support "extended at command set" for sending/receiving SMS messages. It works on frequencies EGSM 900 MHZ, DCS1800 MHZ and PCS 1900 MHZ. SIM 300 features GPRS8

multi-slot class 10/class 8(optional) and supports the GPRS coding schemes. It is a highly flexible plug and play quad band GSM modem that supports features like voice, data, SMS, GPRS and integrated TCP/IP stack.

- f. **EM-506 GPS Receiver:** This is built upon on board voltage regulation, LED status indicator, battery backed RAM and built-in patch antenna including a 6 pin interface cable. It has 48 channels, low power consumption of 40mA at 3.3V and provides superior sensitivity and performance even in urban canyon and dense foliage environment. Network resistance.
- g. **TTL->RS 232 converter:** The complete circuitry is operated with TTL logic level of 0-5V.
- h. **External SDHC:** Maximum of 16 GB.
- i. **Thermal Imaging Camera:** The camera of the proposed model is FLIR TLX Thermal PTZ camera with 640 x 480 resolution and on-board video motion detection (VMD). Based on the recorded intensity of infrared radiation, it produces clear and high contrast images regardless of lighting condition; it can be used to see in complete darkness, through smoke and light fog.
- j. **Traffic Light LED.**

5.0 SOFTWARE SPECIFICATIONS

- a. **Open CV:** Open CV stands for Open computer vision. It is released under a BSD license hence it is free for both academic and commercial use. Open CV is mainly aimed at real-time computer vision and support many languages like C, Perl, and Ruby.
- b. **Visual Studio:** Microsoft visual studio is an integrated development environment [IDE] from Microsoft.
- c. **Raspbian OS:** Raspbian is free operating system based on Debian optimized for the Raspberry device. It is a set of basic programs and utility that Raspberry-pi runs. Raspbian provides more than a pure OS. It comes with over 35000 packages; precompiled software bounded in easy format of installation on Raspberry pi device.

6.0 CONCLUSION

The proposed model discussed in this paper has the intelligence and capability needed to optimize traffic light controller in order to achieve effective road traffic management. It is based on ARM7 microprocessor and Raspberry-pi and employs video and image processing techniques. In this model, traffic control is based on traffic density while it sends traffic information via GSM module. More importantly, It gives priority to emergency vehicles irrespective of the traffic density. In the event of accident, it immediately notifies the emergency centers the accident location using GPS technology. And also, it detects stolen vehicles whose information are already stored in the system and alerts the security personnel accordingly. Traffic offence which is on the rise in the urban cities will be put to stop with the aid of barrier gate embedded in the proposed model. In view of these, the proposed model stands to provide a robust road traffic management and control, reduces response time of emergency personnel, minimizes the traffic offences and reduces cases of vehicle theft. It provides access to traffic data for highway engineers and researchers in Nigeria and beyond. Besides, it is environmental friendly as it is not affected by shadows, wet streets, snow and fog. Therefore, the proposed model is the traffic management solution to urban and smart cities in developing countries like Nigeria.

REFERENCES

- [1] A. Raja and R. Swamalatha (2017), "Smart Traffic Signal by Digital Image Processing Using PCA Algorithm and Edge Detection Techniques", Journal of Engineering and Applied Sciences, ISSN: 1816-949X, 12(22): pp. 6076-6082.
- [2] H. A. Kurdi, Review of Closed Circuit Television (CCTV) Techniques for Vehicles Traffic Management, International Journal of Computer Science & Information Technology (IJCSIT) Vol . 6, No 2, April 2014.
- [3] M. Arora, V. K. Banga, "Real Time Traffic Light Control System", 2nd International Conference on Electrical, Electronics and Civil Engineering (ICEECE'2012), pp. 172-176, Singapore, April 28-29, 2012.

- [4] R. sunder, S. Hebber, and V.Golla, Implimenting intelligence Traffic control system for congestioncontrol, Ambulance Clearness, and Stolen Vehicle Detection " IEEE Sensors Journal, Vol. 15, No.2 February 2015.
- [5] Raspberry pi Web page: [Https://en.wikipedia.org/wiki/Rasspberry-pi](https://en.wikipedia.org/wiki/Rasspberry-pi)[NOV 2015].
- [6] S. Lokesh, T. Prahald Reddy, An Adaptive Traffic Control System Using Rasspberry pi, Vol 3(6): June, 2014
- [7] S.Kulkami and R. Ade, "Intelligent Traffic Control System Implementation for Traffic Violation, Congestion Control and Stolen Vehicle Detection" iJES (2017), Vol.5, No.2, pp. 57-71.
- [8] Traffic Management Centre. [online]. Available: http://www.bangaloretrafficpolice.gov.in/index.php?option=com_content&view=article&id=87&btp=87, accessed 2014.